

Főpép teljesítmény: 2*390kW
 Segédgép teljesítmény: 70 kVA
 Fixpont: 9,2 m
 Merülés menetben: 1,9 m
 Menet közbeni hossz: 74 m

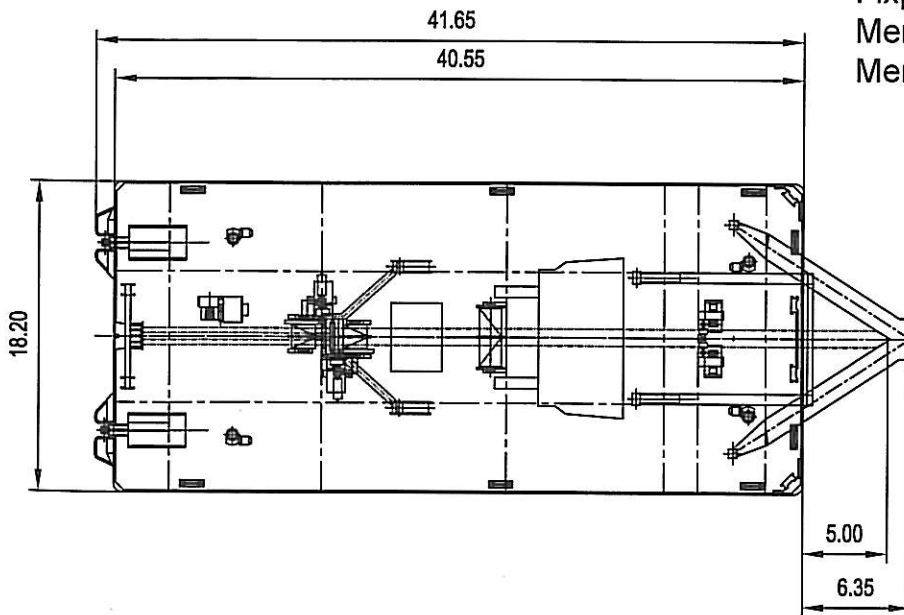

"CLARK"
5 M GÉMKNYŰLÁS

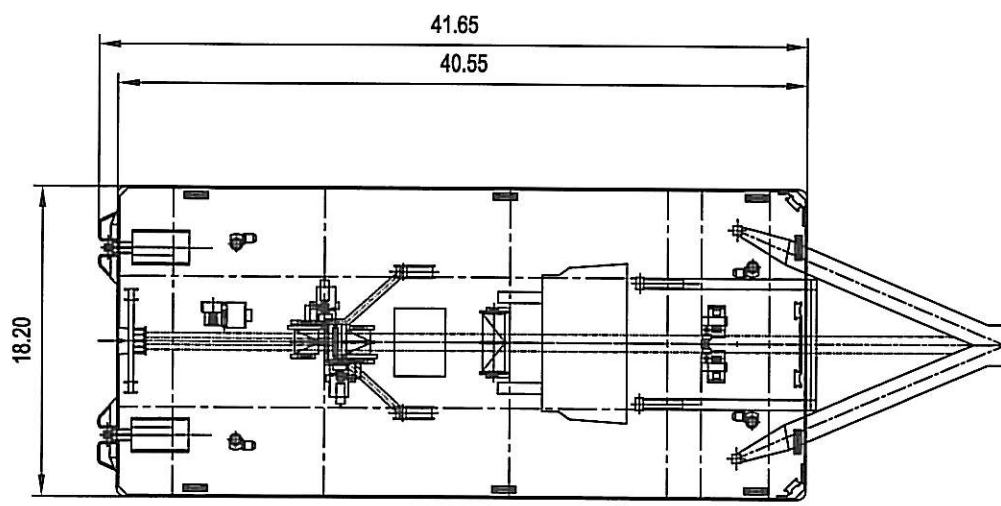
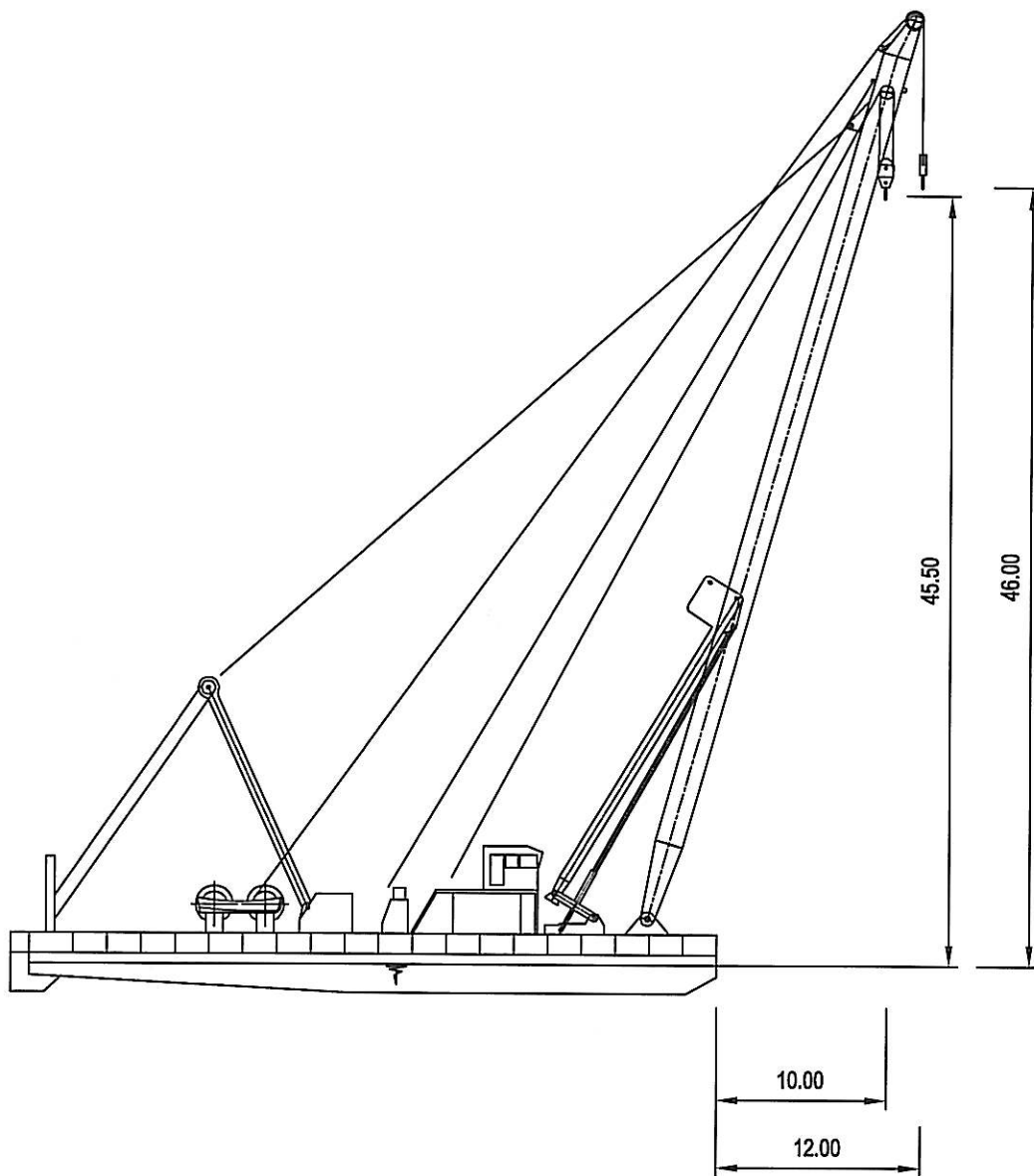

"CLARK"
10 M GÉMKINYÚLÁS

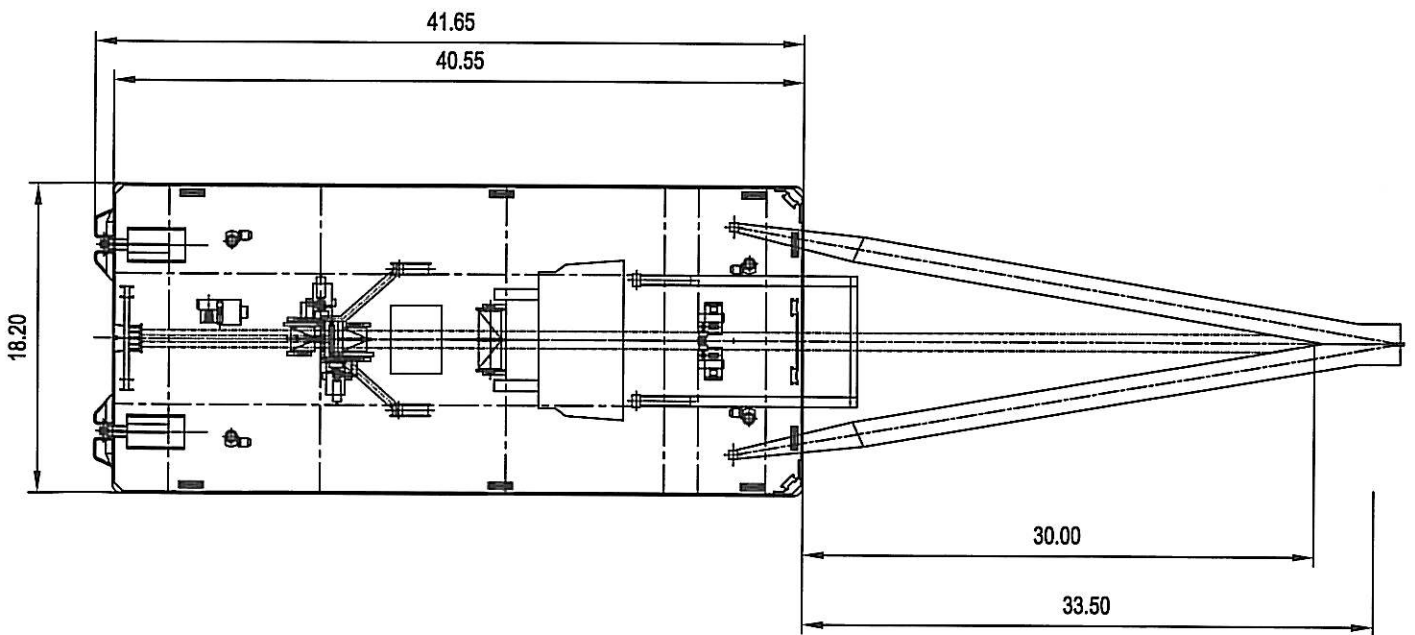
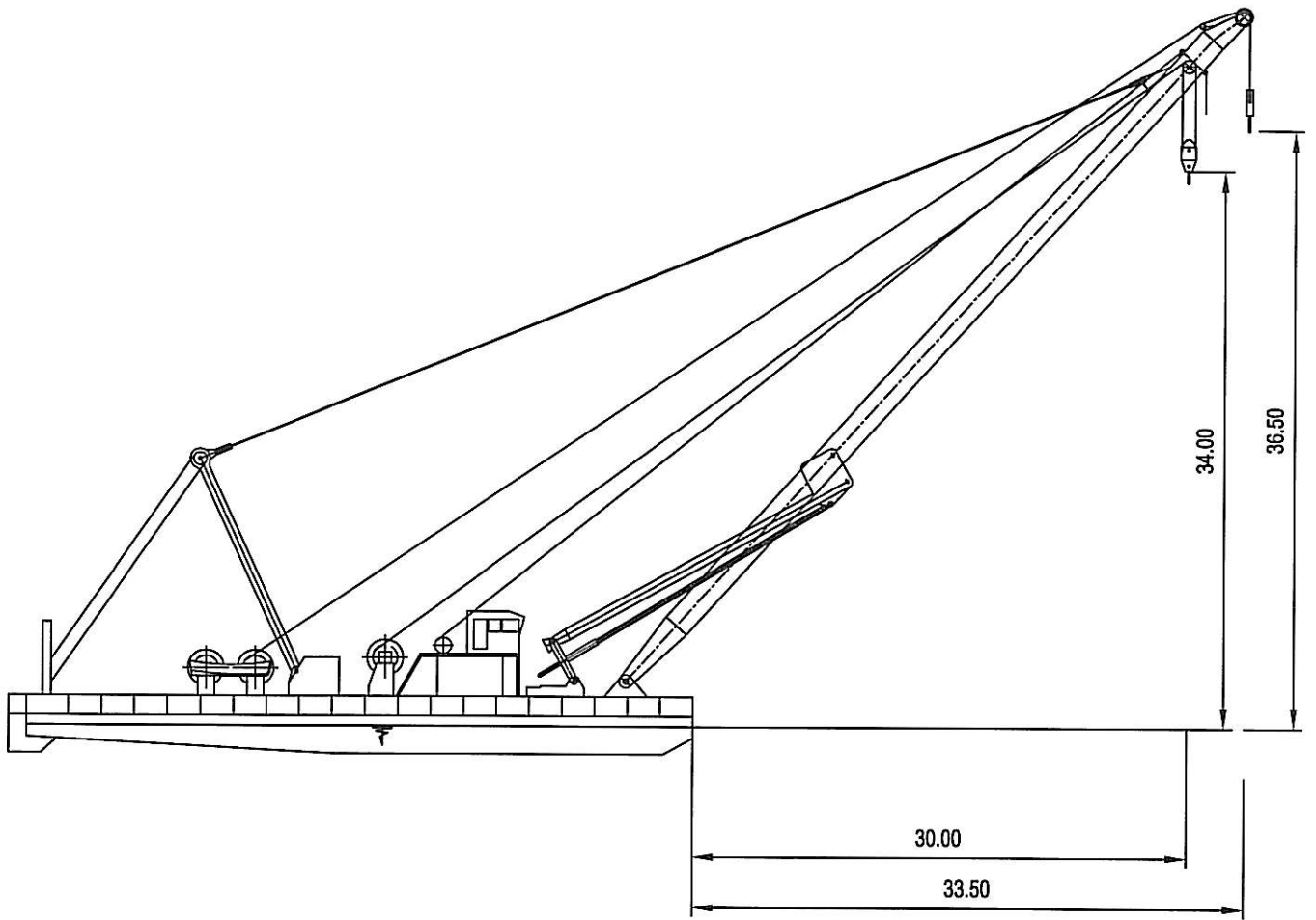

"CLARK"
30 M GÉMKINYÚLÁS

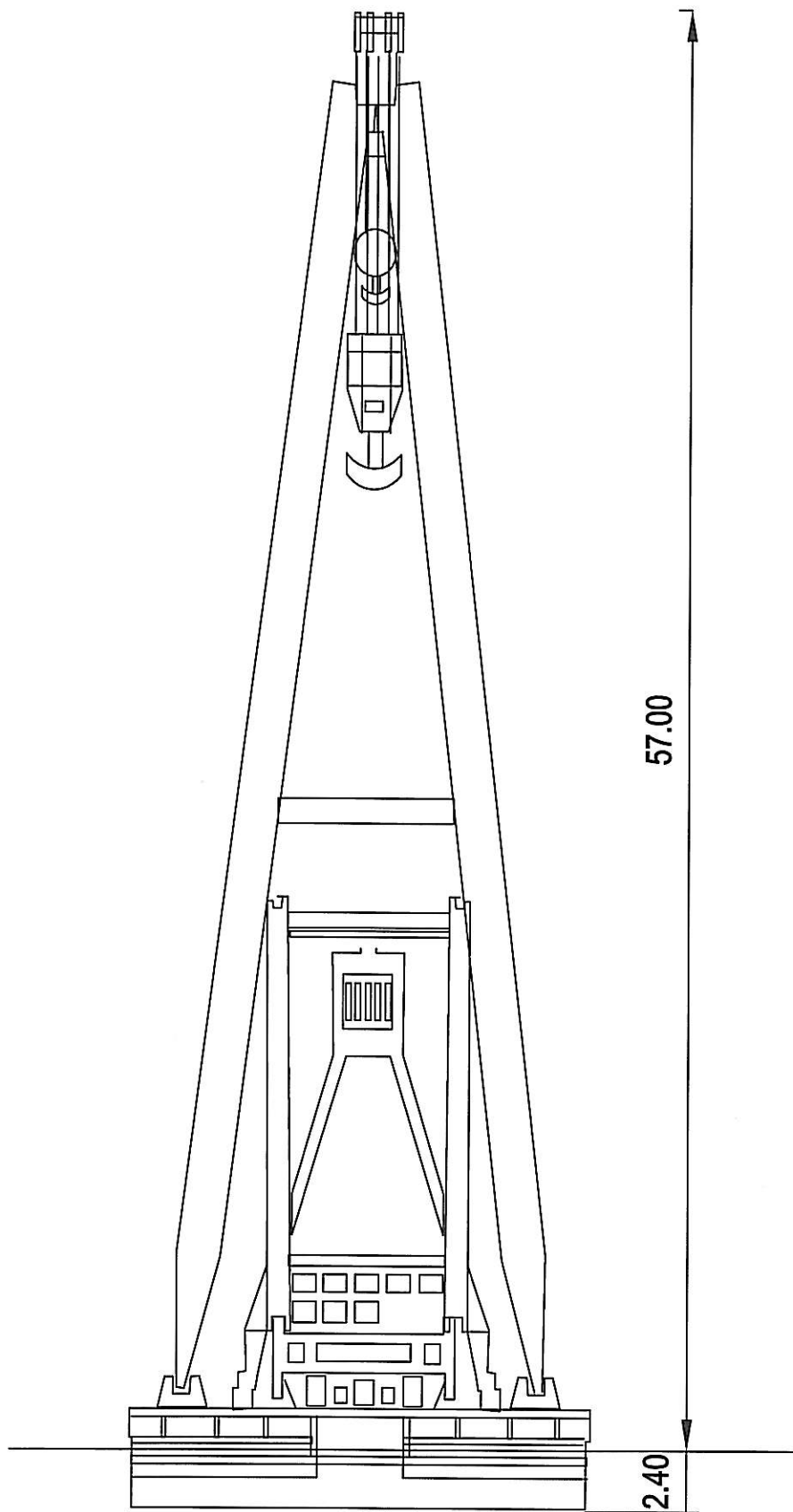

57.00

2.40

"CLARK"
ELŐLNÉZET

200 T MOBILE FLOATING CRANE "ADAM CLARK"

As the biggest swimming crane in Mid-Europe, is really a very decisive floating equipment owing to its significant hoisting height (45 m above water level), jib radius (33m) and load bearing capacity (200 t)

The crane was built in 1980. We have made a significant renovation and reconstruction in 1995, that could render the floating crane more useful, although it was previously, too. Self-propelling has become excellent due to remote control of 2 pcs SCANIA diesel powered VETH VZ-400 CDRIVE. The main diesel engine (2 pcs SCANIA DS 11, 230 kW one by one) also remote controlled, supplying drive for the equipment on the deck through the generators (manoeuvre winches, anchor winches, crane-boom hoisting, crane-boom topple etc.)

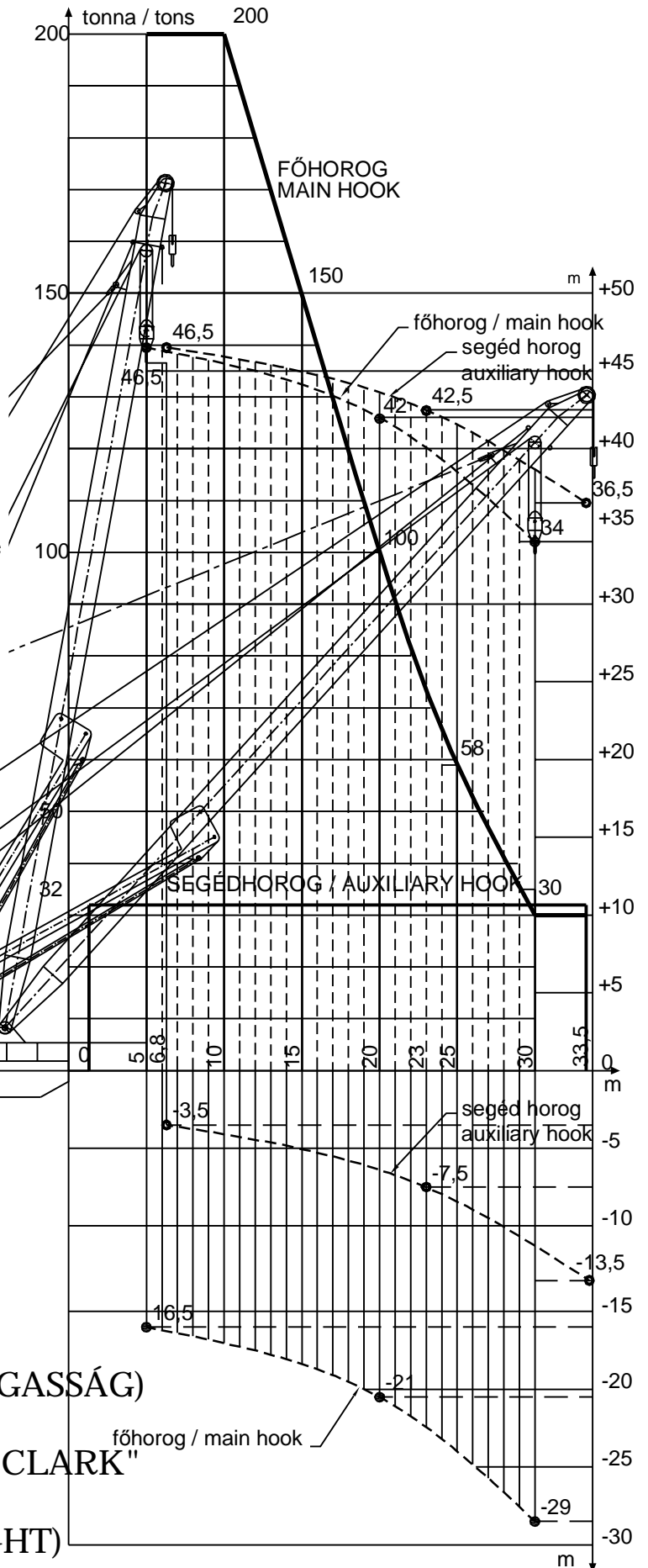
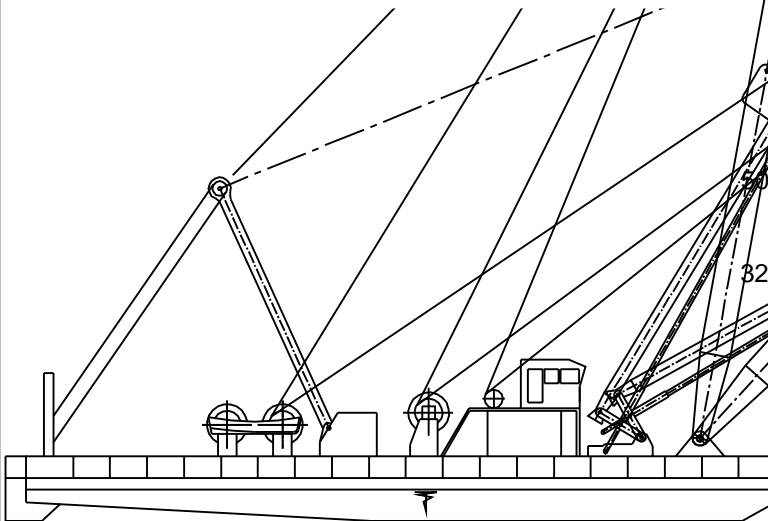

"CLARK ÁDÁM" ÚSZÓDARU
EMELÉSI DIAGRAMOK
(TEHERBÍRÁS ÉS EMELÉSI MAGASSÁG)
/
LIFTING DIAGRAM OF "ADAM CLARK"
FLOATING CRANE
(CAPACITY AND LIFTING HEIGHT)

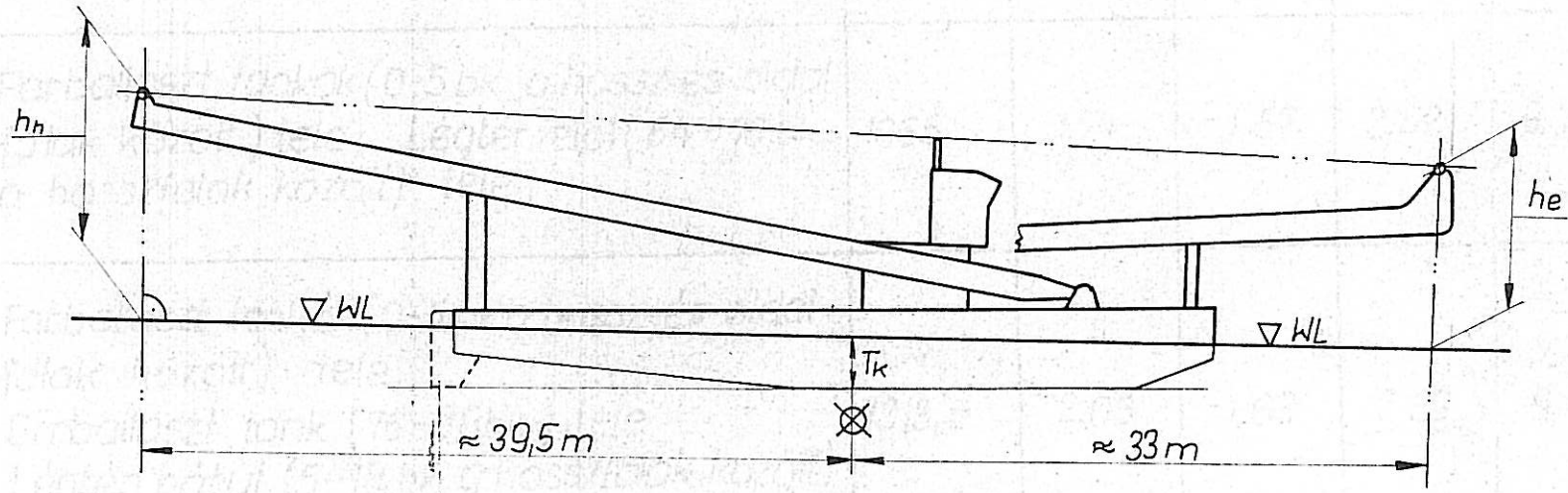

1. ábra

1119 - 110-03 - 10261 Kőrösi N.